

VM300

VIEW FINDER

The View Finder is an optical tool to determine the field view of a lens.

Applications

- 1 To determine the field of view of existing lens.

Select the correct camera format scale, then rotate the View Finder barrel unit the dot coincides with the lens focal length.

The object viewed through the finder is the same as seen by the camera.

Example : In the case when the camera format is 2/3" and the focal length of the lens is 12.5mm, adjust the barrel as shown.

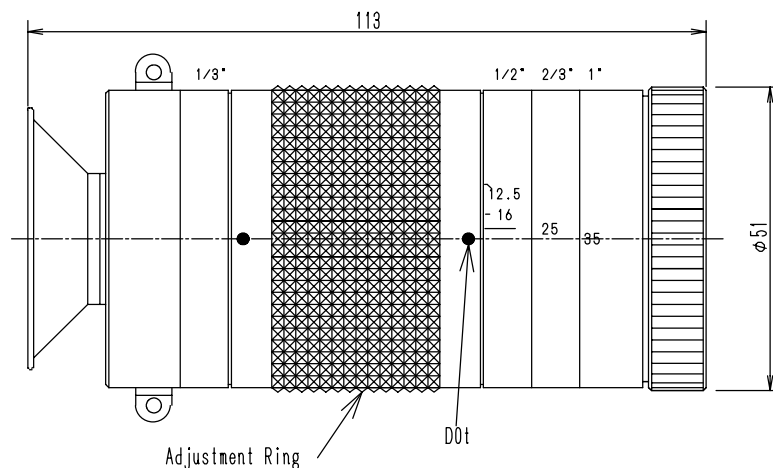

FORMAT

1/4"	1/3"	1/2"	2/3"	1"
3.0	4.0	5.0	6.5	10
		6.5	8.0	12.5
4.5	6.0	8.0	10	16
6.0	8.0	10	12.5	25
		12.5	16	35
		16	25	50
		25	35	75
		35	50	100
		50	75	115
		55		

Table on the Barrel

- 2 To determine what focal length lens to use.

First, look the object through the finder's windows, then turn the barrel to find the desired field of view. Next, using the correct camera format scale, read the lens focal length which coincides with the dot on the barrel.

Example :

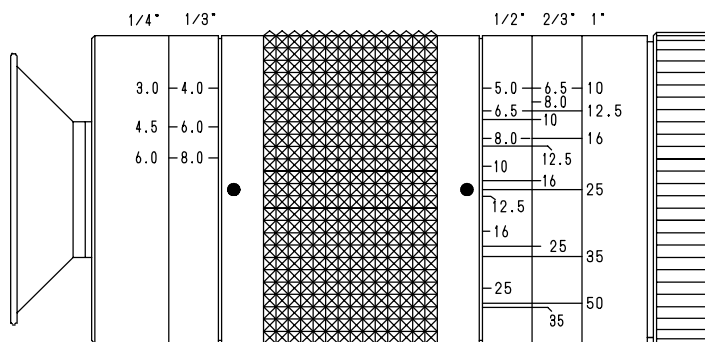

Camera Format	Recommend Focal Length
1"	25.0mm
2/3"	16.0mm
1/2"	12.5mm
1/3"	8.0mm
1/4"	6.0mm

