

MINI DOME COLOR CAMERA ZC-D4039 NHA/ZC-D4039 PHA

Operation Manual

Camera adjustments

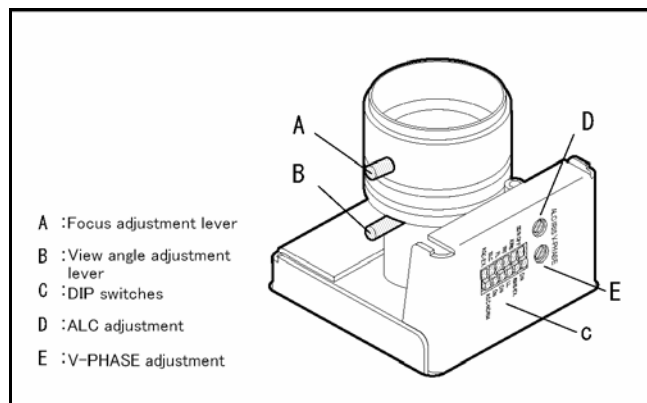

Camera adjustments for the ZC-D4039NHA/PHA

DIP switch settings

The bank of dip switches allow the following settings to be made:

SDN mode (SDN / ON)

When ON the camera operates in monochrome mode in reduced lighting.

Auto White Balance (AWB / AWB.EX)

AWB: The camera operates in the normal Auto White Balance range 2700K~11000K.

AWB EX: The camera runs in the extended Auto White Balance range 2000K~18000K.

Line Lock (INT / LL)

In LL mode, the V-Phase may be adjusted to compensate for connected supply phase differences.

Only applicable for 24VAC supply - otherwise the camera operates with INTERNAL sync.

Flicker less mode (FL / ON)

ON: The Camera reduces flicker in the image under fluorescent lighting.

Back Light Compensation (BLC)

When set ON, this option improves the camera response to strong, unwanted lighting effects behind the required subject.

Low Light Sensitivity (AGC-EX)

When set to EX sensitivity in low light is increased.

Focus & view angle adjustment

Twist the levers on the side of the varifocal camera to adjust the focus and view angle settings.

TIP: If necessary, perform the final focus through the dome cover. Hold it to the lens reversed to confirm the final results.

Vertical phase adjustment

Use this adjustment when using an AC supply to align the camera phase with that of the supply.

Iris adjustment

This is factory set and should not normally require adjustment except to compensate for excessive image blooming.

ZC-D4039NHA/PHA camera specifications

Type / Format	NTSC	PAL
Scanning Element	2:1 Interlace, H15.750 KHz/V:59.94 Hz	2:1 Interlace, H15.625 KHz/V:50 Hz
Image Picture Element	1/3" Interline CCD	
Effective Picture Element	768(H) × 494(V)	752(H) × 582(V)
Approximate pixels	380K	430K
Resolution (TV lines)	540 (normal)	
Minimum Illumination	1.0 lx @ F1.2	
S/N Ratio	50 dB	
AGC.EX Gain	30 dB	
AGC Preset Gain	26 dB	
Back Light Compensation	Central area for auto iris	
Exposure Control	DC Auto IRIS Drive	
Sync System	Internal/Line lock	
Line Lock (Phase Adj. Range)	0°~270°	
Line Lock (Frequency Range)	60 Hz ± 1 Hz	50 Hz ± 1 Hz
Gamma Compensation	0.45	
Video Output	1.0 Vpp, 75 ohm Unbalanced	
White Balance	Automatic White Balance	
AWB Normal Range	2700K - 11000K	
AWB.EX Range	2000K - 18000K	
Power Range	AC: 24 VAC ± 20% or DC: 12 VDC -10% +20%	
Power Consumption	4W	
Operating Temperature	-10°C to +50°C	
Storage Temperature	-35°C to +60°C	
External Dimensions	120(φ)mm x 100(H)mm	

Lens Specifications

Focal Length	3.0-9.0 mm	
F-No.	F1.2	
Iris Range	F1.2~F360	
Minimum Object Distance	0.5 m	
Angle Of View	Diagonal	116.2°~39.7°
	Horizontal	90.0°~31.8°
	Vertical	66.2°~23.9°
Lens Type	Vari-focal	



English

Disposal of your old appliance

1. When this crossed-out wheeled bin symbol is attached to a product it means the product is covered by the European Directive 2002/96/EC.
2. All electrical and electronic products should be disposed of separately from the municipal waste stream via designated collection facilities appointed by the government or the local authorities.
3. The correct disposal of your old appliance will help prevent potential negative consequences for the environment and human health.
4. For more detailed information about disposal of your old appliance, please contact your city office, waste disposal service or the shop where you purchased the product.

Français/French

Élimination de votre ancien appareil

1. Ce symbole, représentant une poubelle sur roulettes barrée d'une croix, signifie que le produit est couvert par la directive européenne 2002/96/EC.
2. Tous les produits électriques et électroniques doivent être éliminés séparément de la chaîne de collecte municipale des ordures, par l'intermédiaire des installations de collecte prescrites et désignées par le gouvernement ou les autorités locales.
3. Une élimination conforme aux instructions aidera à réduire les conséquences négatives et risquées éventuelles pour l'environnement et la santé humaine.
4. Pour plus d'informations concernant l'élimination de votre ancien appareil, veuillez contacter votre mairie, le service des ordures ménagères ou encore le magasin où vous avez acheté ce produit.

Deutsch/German

Entsorgung von Altgeräten

1. Wenn dieses Symbol eines durchgestrichenen Abfallimers auf einem Produkt angebracht ist, unterliegt dieses Produkt der europäischen Richtlinie 2002/96/EC.
2. Alle Elektro- und Elektronik-Altgeräte müssen getrennt vom Hausmüll über die dafür staatlich vorgesehenen Stellen entsorgt werden.
3. Mit der ordnungsgemäßen Entsorgung des alten Geräts vermeiden Sie Umweltschäden und eine Gefährdung der persönlichen Gesundheit.
4. Weitere Informationen zur Entsorgung des alten Geräts erhalten Sie bei der Stadtverwaltung, beim Entsorgungsamts oder in dem Geschäft, wo Sie das Produkt erworben haben.

Italiano/Italian

INFORMAZIONE AGLI UTENTI

Ai sensi dell'art. 13 del Decreto Legislativo 25 luglio 2005, n. 151 "Attuazione delle direttive 2002/95/CE, 2002/96/CE e 2003/108/CE, relative alla riduzione dell'uso di sostanze pericolose nelle apparecchiature elettriche ed elettroniche, nonché allo smaltimento dei rifiuti"

Il simbolo del cassonetto barrato riportato sull'apparecchiatura o sulla sua confezione indica che il prodotto alla fine della propria vita utile deve essere raccolto separatamente dagli altri rifiuti.

La raccolta differenziata della presente apparecchiatura giunta a fine vita è organizzata e gestita dal produttore. L'utente che vorrà disfarsi della presente apparecchiatura dovrà quindi contattare il produttore e seguire il sistema che questo ha adottato per consentire la raccolta separata dell'apparecchiatura giunta a fine vita.

L'adeguata raccolta differenziata per l'avvio successivo dell'apparecchiatura dismessa al riciclaggio, al trattamento e allo smaltimento ambientalmente compatibile contribuisce ad evitare possibili effetti negativi sull'ambiente e sulla salute e favorisce il reimpiego e/o il riciclo dei materiali di cui è composta l'apparecchiatura. Lo smaltimento abusivo del prodotto da parte del detentore comporta l'applicazione delle sanzioni amministrative previste dalla normativa vigente.

Polski/Polish

Utylizacja starych urządzeń

1. Kiedy do produktu dołączony jest niniejszy przekreślony symbol kołowego pojemnika na śmieci, oznacza to, że produkt jest objęty europejską dyrektywą 2002/96/EC.
2. Wszystkie elektryczne i elektroniczne produkty powinny być utylizowane niezależnie od odpadów miejskich, z wykorzystaniem przeznaczonych do tego miejsc składowania wskazanych przez rząd lub miejscowe władze.
3. Właściwy sposób utylizacji starego urządzenia pomoże zapobiec potencjalnie negatywnemu wpływowi na zdrowie i środowisko.
4. Aby uzyskać więcej informacji o sposobach utylizacji starych urządzeń, należy skontaktować się z władzami lokalnymi, przedsiębiorstwem zajmującym się utylizacją odpadów lub sklepem, w którym produkt został kupiony.

Português/Portuguese

Eliminação do seu antigo aparelho

1. Quando este símbolo de latão cruzado estiver afixado a um produto, significa que o produto é abrangido pela Directiva Europeia 2002/96/EC.
2. Todos os produtos eléctricos e electrónicos devem ser eliminados separadamente da coleta de lixo municipal através de pontos de recolha designados, facilitados pelo governo ou autoridades locais.
3. A eliminação correcta do seu aparelho antigo ajuda a evitar potenciais consequências negativas para o ambiente e para a saúde humana.
4. Para obter informações mais detalhadas acerca da eliminação do seu aparelho antigo, contacte as autoridades locais, um serviço de eliminação de resíduos ou a loja onde comprou o produto.

Español/Spanish

Cómo deshacerse de aparatos eléctricos y electrónicos viejos

1. Si en un producto aparece el símbolo de un contenedor de basura tachado, significa que éste se acoge a la Directiva 2002/96/EC.
2. Todos los aparatos eléctricos o electrónicos se deben desechar de forma distinta del servicio municipal de recogida de basura, a través de puntos de recogida designados por el gobierno o las autoridades locales.
3. La correcta recogida y tratamiento de los dispositivos inservibles contribuye a evitar riesgos potenciales para el medio ambiente y la salud pública.
4. Para obtener más información sobre cómo deshacerse de sus aparatos eléctricos y electrónicos viejos, póngase en contacto con su ayuntamiento, el servicio de recogida de basuras o el establecimiento donde adquirió el producto.

FCC INFORMATION

WARNING: This equipment has been tested and found to comply with the limits for a Class B digital device, pursuant to Part 15 of the FCC Rules. These limits are designed to provide reasonable protection against harmful interference in a residential installation. This equipment generates, uses, and can radiate radio frequency energy and, if not installed and used in accordance with the instructions, may cause harmful interference to radio communications. However, there is no guarantee that interference will not occur in a particular installation. If this equipment does cause harmful interference to radio or television reception, which can be determined by turning the equipment off and on, the user is encouraged to try to correct the interference by one or more of the following measures:

- Reorient or relocate the receiving antenna.
- Increase the separation between the equipment and receiver.
- Connect the equipment into an outlet on a circuit different from that to which the receiver is connected.
- Consult the dealer or an experienced radio/television technician for help.

Any changes or modifications not expressly approved by the party responsible for compliance could void the user's authority to operate the equipment.

This device complies with Part 15 of the FCC Rules. Operation is subject to the following two conditions: (1) this device may not cause harmful interference, and (2) this device must accept any interference received, including interference that may cause undesired operation.

This Class B digital apparatus complies with Canadian ICES-003.



The CE Marking is a Directive Conformity mark of the European Union (EU).

MINI DOME CAMERA ZC-D4000 series

Enclosure Installation Sheet

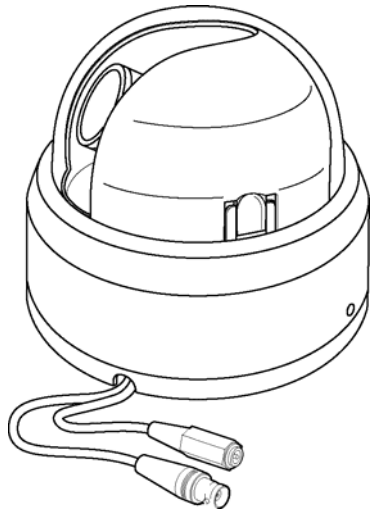

Precautions

- Do not attempt to disassemble the camera module mounted within the dome. There are no user-serviceable parts within the camera module. Have all servicing carried out by to qualified service personnel.
- Handle the camera with care. Avoid dropping or shaking it. Improper handling or storage could damage the camera.
- Irrespective of whether the camera is in use or not, never face it towards the sun. Use caution when operating the camera in the vicinity of spotlights or other bright lights and light-reflecting objects.
- Do not operate the camera beyond its temperature, humidity or power source ratings. Please refer to the environmental information provided overleaf.

Methods for mounting the enclosure

There are three ways to mount and fix the dome enclosure:

- A:** Surface mount using screws
- B:** Surface mount with the optional Quick Install Kit

Note: Always use the template provided

Packing list

In addition to this installation sheet:

- 1 × Torx driver
- 3 D5 fastening screws
- 3 Wall plug
- T2 fastening screw
- 1/2" Cable Entry Grommet
- 3/4" Cable Entry Grommet

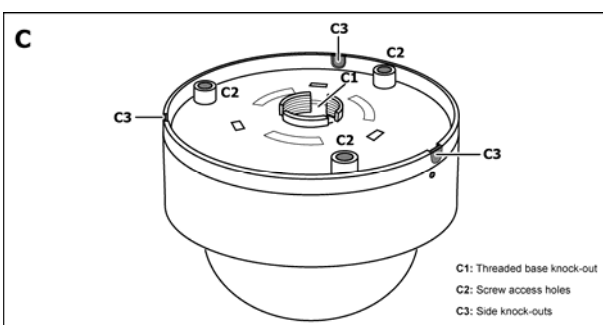
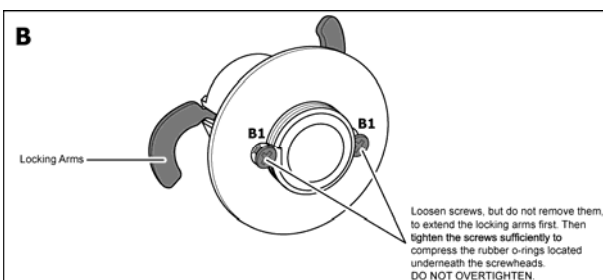
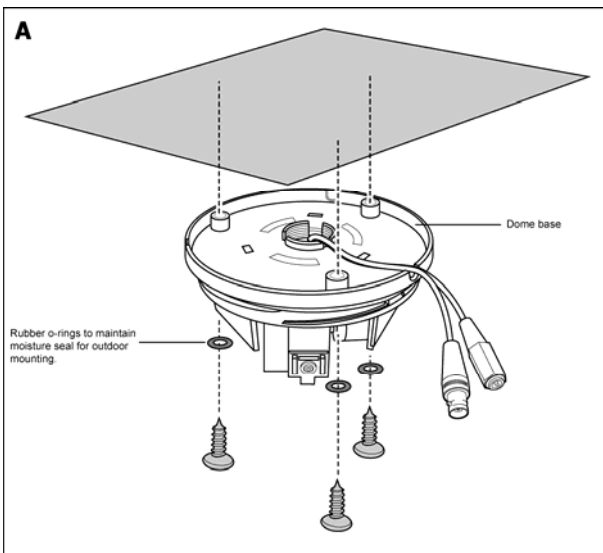

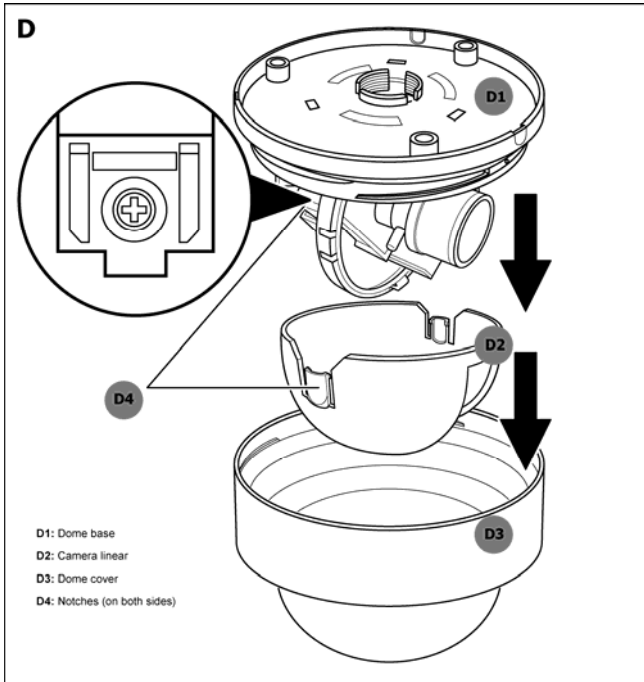

Installing the dome enclosure

1. Remove the dome cover and the camera linear

Gently turn the dome cover counter-clockwise to unlock and pull free of the dome base. Remove the camera linear by gently pulling it free of the two notches (D4) in the camera base (see fig. D)

2. Use the template to mark and prepare the mounting area

This installation sheet is designed to maintain the IP and NEMA rating independent of the chosen installation method. Therefore, all mounting access positions are sealed until they are ready to be used. When mounting the dome to a ceiling or wall using screws, use the template to cut a hole as the circle marked "T5" with a hole cutter.

3. Open the required knock-out panel

Use a sharp knife or side cutter pliers to cut one of the side knock-outs (C3) to the size required to allow cable insertion. Be careful not to hurt yourself or damage the camera when using knives and side cutter pliers.

4. Mount the dome enclosure

Using one of the mounting schemes discussed overleaf (Methods for mounting the enclosure), fix the dome enclosure in place.

5. Connect the connectors

All wires have been connected to the circuit board sealed on the dome base. When the enclosure is mounted securely to a surface, connect your video out and power in the cables to the G1 and G2 connectors. A service jack socket is also provided for temporary video connection when focusing the camera, using an optional Service jack socket.

Important: Use only a Class 2 certified power supply.

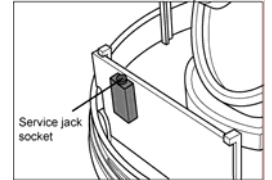

6. Adjust the camera position

You can adjust the focusing position by rotating and panning the camera base (see fig. E)

7. Install the camera liner

Carefully fit the camera linear (F1) over the camera base so that it snaps into place as shown in fig F and does not obstruct the camera lens.

8. Replace the dome cover

Replace the dome cover (F2) and rotate to close it as shown in fig.F. Use the supplied T2 screw to secure the whole enclosure (see fig. G)

9. Install the Quick Mount Kit (optional) (see fig.H)

- Use the screws to adjust the position of the two locking arms on the Quick Mount adapter.
- Thread cables through the Quick Mount adapter (H1) and install it onto the dome enclosure.
- Attach Camera to Quick Mount Install Adapter using the thread.

