

VANDAL RESISTANT CAMERA ZC-DT4039 NHA/ZC-DT4039 PHA

Operation Manual

Camera adjustments

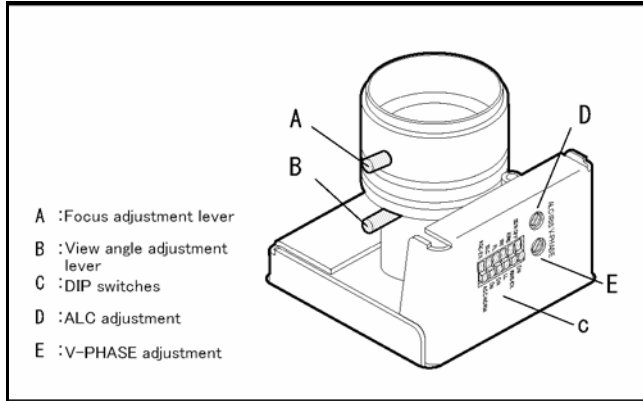

Camera adjustments for the ZC-DT4039NHA/PHA

DIP switch settings

The bank of dip switches allow the following settings to be made:

SDN mode (SDN / ON)

When ON the camera operates in monochrome mode in reduced lighting.

Auto White Balance (AWB / AWB.EX)

AWB: The camera operates in the normal Auto White Balance range 2700K~11000K.

AWB EX: The camera runs in the extended Auto White Balance range 2000K~18000K.

Line Lock (INT / LL)

In LL mode, the V-Phase may be adjusted to compensate for connected supply phase differences.

Only applicable for 24VAC supply - otherwise the camera operates with INTERNAL sync.

Flicker less mode (FL / ON)

ON: The Camera reduces flicker in the image under fluorescent lighting.

Back Light Compensation (BLC)

When set ON, this option improves the camera response to strong, unwanted lighting effects behind the required subject.

Low Light Sensitivity (AGC-EX)

When set to EX sensitivity in low light is increased.

Focus & view angle adjustment

Twist the levers on the side of the varifocal camera to adjust the focus and view angle settings.

TIP: If necessary, perform the final focus through the dome cover. Hold it to the lens reversed to confirm the final results.

Vertical phase adjustment

Use this adjustment when using an AC supply to align the camera phase with that of the supply.

Iris adjustment

This is factory set and should not normally require adjustment except to compensate for excessive image blooming.

ZC-DT4039NHA/PHA camera specifications

Type / Format	NTSC	PAL
Scanning Element	2:1 Interlace, H15.750 KHz/V:59.94 Hz	2:1 Interlace, H15.625 KHz/V:50 Hz
Image Picture Element	1/3" Interline CCD	
Effective Picture Element	768(H) × 494(V)	752(H) × 582(V)
Approximate pixels	380K	430K
Resolution (TV lines)	540 (normal)	
Minimum Illumination	1.0 lx @ F1.2	
S/N Ratio	50 dB	
AGC.EX Gain	30 dB	
AGC Preset Gain	26 dB	
Back Light Compensation	Central area for auto iris	
Exposure Control	DC Auto IRIS Drive	
Sync System	Internal/Line lock	
Line Lock (Phase Adj. Range)	0°~270°	
Line Lock (Frequency Range)	60 Hz ± 1 Hz	50 Hz ± 1 Hz
Gamma Compensation	0.45	
Video Output	1.0 Vpp, 75 ohm Unbalanced	
White Balance	Automatic White Balance	
AWB Normal Range	2700K - 11000K	
AWB.EX Range	2000K - 18000K	
Power Range	AC: 24 VAC ± 20% or DC: 12 VDC -10% +20%	
Power Consumption	4W	
Operating Temperature	-10°C to +50°C	
Storage Temperature	-35°C to +60°C	
External Dimensions	120(φ)mm x 100(H)mm	

Lens Specifications

Focal Length	3.0-9.0 mm	
F-No.	F1.2	
Iris Range	F1.2~F360	
Minimum Object Distance	0.5 m	
Angle Of View	Diagonal	116.2°~39.7°
	Horizontal	90.0°~31.8°
	Vertical	66.2°~23.9°
Lens Type	Vari-focal	



English

Disposal of your old appliance

1. When this crossed-out wheeled bin symbol is attached to a product it means the product is covered by the European Directive 2002/96/EC.
2. All electrical and electronic products should be disposed of separately from the municipal waste stream via designated collection facilities appointed by the government or the local authorities.
3. The correct disposal of your old appliance will help prevent potential negative consequences for the environment and human health.
4. For more detailed information about disposal of your old appliance, please contact your city office, waste disposal service or the shop where you purchased the product.

Français/French

Élimination de votre ancien appareil

1. Ce symbole, représentant une poubelle sur roulettes barrée d'une croix, signifie que le produit est couvert par la directive européenne 2002/96/EC.
2. Tous les produits électriques et électroniques doivent être éliminés séparément de la chaîne de collecte municipale des ordures, par l'intermédiaire des installations de collecte prescrites et désignées par le gouvernement ou les autorités locales.
3. Une élimination conforme aux instructions aidera à réduire les conséquences négatives et risquées éventuelles pour l'environnement et la santé humaine.
4. Pour plus d'informations concernant l'élimination de votre ancien appareil, veuillez contacter votre mairie, le service des ordures ménagères ou encore le magasin où vous avez acheté ce produit.

Deutsch/German

Entsorgung von Altgeräten

1. Wenn dieses Symbol eines durchgestrichenen Abfallimers auf einem Produkt angebracht ist, unterliegt dieses Produkt der europäischen Richtlinie 2002/96/EC.
2. Alle Elektro- und Elektronik-Altgeräte müssen getrennt vom Hausmüll über die dafür staatlich vorgesehenen Stellen entsorgt werden.
3. Mit der ordnungsgemäßen Entsorgung des alten Geräts vermeiden Sie Umweltschäden und eine Gefährdung der persönlichen Gesundheit.
4. Weitere Informationen zur Entsorgung des alten Geräts erhalten Sie bei der Stadtverwaltung, beim Entsorgungsamt oder in dem Geschäft, wo Sie das Produkt erworben haben.

Italiano/Italian

INFORMAZIONE AGLI UTENTI

Ai sensi dell'art. 13 del Decreto Legislativo 25 luglio 2005, n. 151 "Attuazione delle direttive 2002/95/CE, 2002/96/CE e 2003/108/CE, relative alla riduzione dell'uso di sostanze pericolose nelle apparecchiature elettriche ed elettroniche, nonché allo smaltimento dei rifiuti"

Il simbolo del cassonetto barrato riportato sull'apparecchiatura o sulla sua confezione indica che il prodotto alla fine della propria vita utile deve essere raccolto separatamente dagli altri rifiuti.

La raccolta differenziata della presente apparecchiatura giunta a fine vita è organizzata e gestita dal produttore. L'utente che vorrà disfarsi della presente apparecchiatura dovrà quindi contattare il produttore e seguire il sistema che questo ha adottato per consentire la raccolta separata dell'apparecchiatura giunta a fine vita.

L'adeguata raccolta differenziata per l'avvio successivo dell'apparecchiatura dismessa al riciclaggio, al trattamento e allo smaltimento ambientalmente compatibile contribuisce ad evitare possibili effetti negativi sull'ambiente e sulla salute e favorisce il reimpiego e/o il riciclo dei materiali di cui è composta l'apparecchiatura. Lo smaltimento abusivo del prodotto da parte del detentore comporta l'applicazione delle sanzioni amministrative previste dalla normativa vigente.

Polski/Polish

Utylizacja starych urządzeń

1. Kiedy do produktu dołączony jest niniejszy przekreślony symbol kołowego pojemnika na śmieci, oznacza to, że produkt jest objęty europejską dyrektywą 2002/96/EC.
2. Wszystkie elektryczne i elektroniczne produkty powinny być utylizowane niezależnie od odpadów miejskich, z wykorzystaniem przeznaczonych do tego miejsc składowania wskazanych przez rząd lub miejscowe władze.
3. Właściwy sposób utylizacji starego urządzenia pomoże zapobiec potencjalnie negatywnemu wpływowi na zdrowie i środowisko.
4. Aby uzyskać więcej informacji o sposobach utylizacji starych urządzeń, należy skontaktować się z władzami lokalnymi, przedsiębiorstwem zajmującym się utylizacją odpadów lub sklepem, w którym produkt został kupiony.

Português/Portuguese

Eliminação do seu antigo aparelho

1. Quando este símbolo de latão cruzado estiver afixado a um produto, significa que o produto é abrangido pela Directiva Europeia 2002/96/EC.
2. Todos os produtos eléctricos e electrónicos devem ser eliminados separadamente da coleta de lixo municipal através de pontos de recolha designados, facilitados pelo governo ou autoridades locais.
3. A eliminação correcta do seu aparelho antigo ajuda a evitar potenciais consequências negativas para o ambiente e para a saúde humana.
4. Para obter informações mais detalhadas acerca da eliminação do seu aparelho antigo, contacte as autoridades locais, um serviço de eliminação de resíduos ou a loja onde comprou o produto.

Español/Spanish

Cómo deshacerse de aparatos eléctricos y electrónicos viejos

1. Si en un producto aparece el símbolo de un contenedor de basura tachado, significa que éste se acoge a la Directiva 2002/96/EC.
2. Todos los aparatos eléctricos o electrónicos se deben desechar de forma distinta del servicio municipal de recogida de basura, a través de puntos de recogida designados por el gobierno o las autoridades locales.
3. La correcta recogida y tratamiento de los dispositivos inservibles contribuye a evitar riesgos potenciales para el medio ambiente y la salud pública.
4. Para obtener más información sobre cómo deshacerse de sus aparatos eléctricos y electrónicos viejos, póngase en contacto con su ayuntamiento, el servicio de recogida de basuras o el establecimiento donde adquirió el producto.

FCC INFORMATION

WARNING: This equipment has been tested and found to comply with the limits for a Class B digital device, pursuant to Part 15 of the FCC Rules. These limits are designed to provide reasonable protection against harmful interference in a residential installation. This equipment generates, uses, and can radiate radio frequency energy and, if not installed and used in accordance with the instructions, may cause harmful interference to radio communications. However, there is no guarantee that interference will not occur in a particular installation. If this equipment does cause harmful interference to radio or television reception, which can be determined by turning the equipment off and on, the user is encouraged to try to correct the interference by one or more of the following measures:

- Reorient or relocate the receiving antenna.
- Increase the separation between the equipment and receiver.
- Connect the equipment into an outlet on a circuit different from that to which the receiver is connected.
- Consult the dealer or an experienced radio/television technician for help.

Any changes or modifications not expressly approved by the party responsible for compliance could void the user's authority to operate the equipment.

This device complies with Part 15 of the FCC Rules. Operation is subject to the following two conditions: (1) this device may not cause harmful interference, and (2) this device must accept any interference received, including interference that may cause undesired operation.

This Class B digital apparatus complies with Canadian ICES-003.



The CE Marking is a Directive Conformity mark of the European Union (EU).

VANDAL RESISTANT DOME CAMERA

ZC-D4000 series

Enclosure Installation Manual

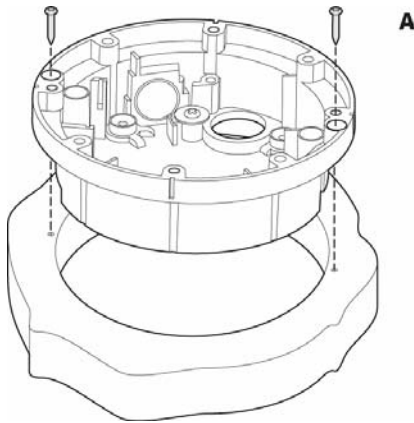
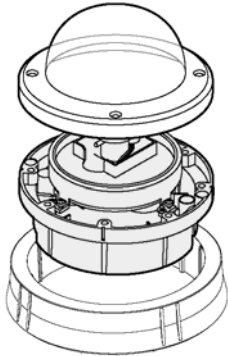

A

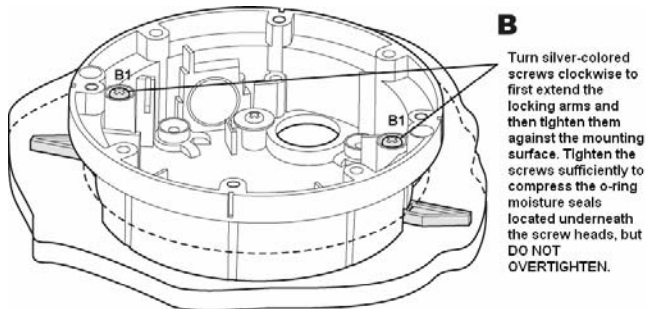

B

Turn silver-colored screws clockwise to first extend the locking arms and then tighten them against the mounting surface. Tighten the screws sufficiently to compress the o-ring moisture seals located underneath the screw heads, but **DO NOT OVERTIGHTEN.**

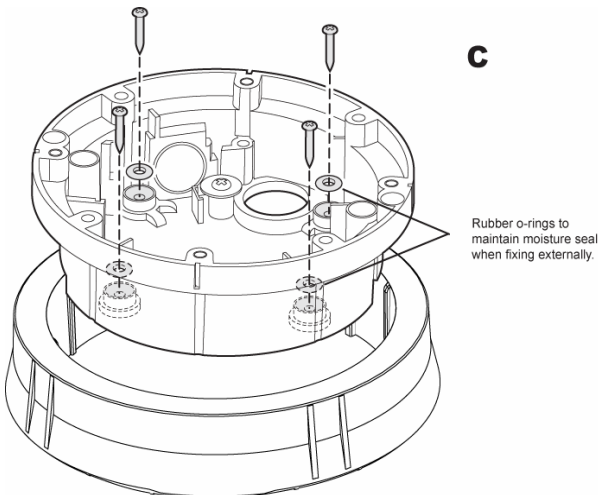

C

Rubber o-rings to maintain moisture seal when fixing externally.

Precautions

- Do not attempt to dismantle the camera module mounted within the dome. There are no user serviceable parts within the camera module. Refer servicing to qualified personnel.
- Handle the camera with care. Do not abuse the camera. Avoid striking or shaking it. Improper handling and storage could damage the camera.
- Do not operate the camera outside of its temperature, humidity or power source rating range. Please refer to the environmental information provided overleaf.

Methods for mounting the enclosure

There are three main ways to mount and attach the dome enclosure:

A: Flush mount using screws

B: Flush mount using locking arms

C: Surface mount using the outer ring

Note: Always use the template provided

When mounting externally

When mounting externally using the four base holes, use the supplied rubber o-rings (shown in C) within the mounting holes to ensure a moisture-resistant seal. Make sure that the cable entry through either knockout panels is suitably sealed against moisture ingress. Regardless of whether the locking arms are used for installation or folded away (in favor of another installation method), always make sure the locking arm screws are tight enough to compress the rubber o-rings to maintain the moisture seal.

Packing list

- Vandal Resistant Dome Enclosure
- 4 #12 x 1 1/2 mounting screws
- 4 rubber sealing o-rings
- 4 wall plugs
- 1 Torx bit
- 1 Camera chassis & liner
- 1 wire ended power adaptor lead
- 4 plastic screw caps to conceal the dome cover screws
- 1 large rubber gasket (fitted between enclosure and outer ring)
- 1 3/4" sealing plug (1/2" sealing plug fitted to enclosure)
- 1 1/2" and 1 3/4" cable entry grommets

Weather resistance

IP66 Rated

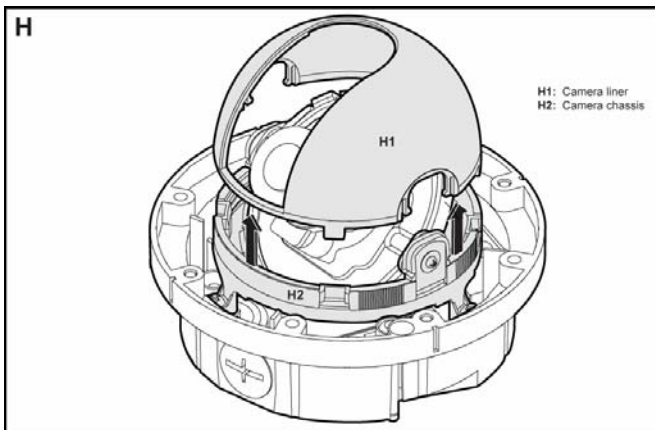
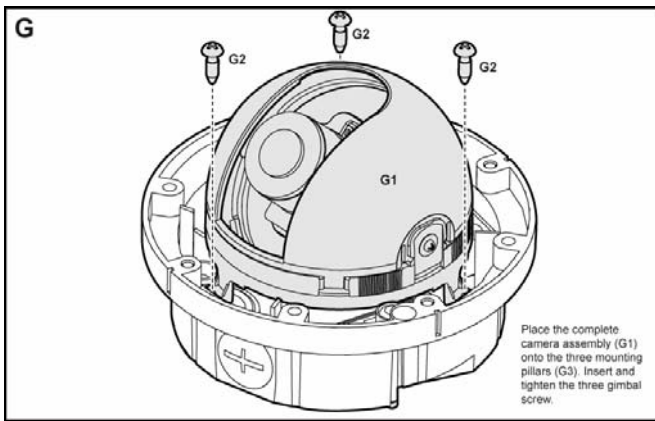
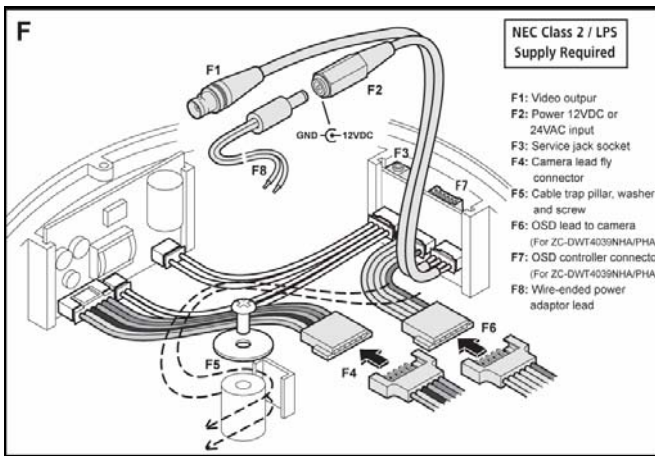
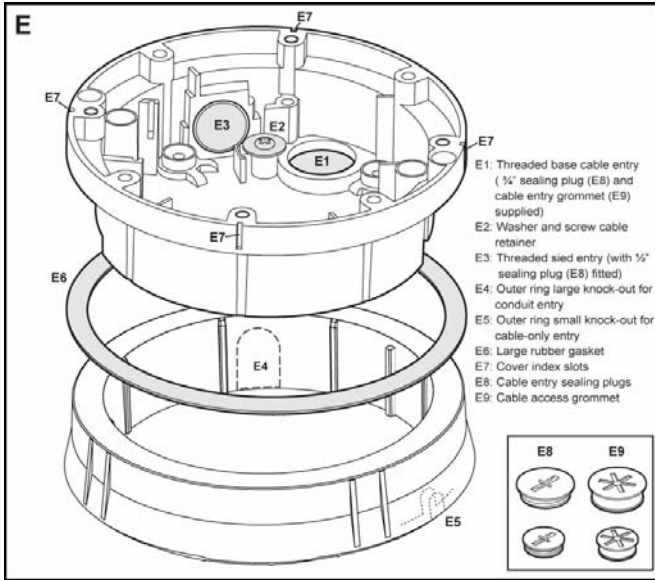

Installing the dome enclosure

1. Remove the dome cover

Use the supplied Torx driver to loosen (but not remove) the four cover screws. The screws are captive and will be retained in the lid.

2. Use the template to mark and prepare the mounting area

The vandal resistant dome was designed to maintain their IP and NEMA ratings independent of the install method chosen. Therefore, all mounting access positions are sealed until they are ready to be used. For example when surface-mounting the housing, first knock out the screw access holes that correspond to the template marks "T1". This can be done using a crosshead screwdriver.

3. Open the required knock-out panel

Carefully drill (or tap out) either the base knock-out (E1) or internal side knock-out (E3) to the size required to allow cable entry. When surface mounting and using the side knock-out (E3), open the cut out (E4) within the outer ring to the required size by cutting away excess material with a hole cutter, sharp knife or side cutters.

4. Mount the dome enclosure

Using one of the mounting schemes discussed overleaf (methods for mounting the enclosure), fix the dome enclosure (and outer ring, if necessary) in place. When flush mounting or surface mounting using the outer ring, ensure that the large rubber gasket (E6) is in place under the lip of the dome enclosure.

IMPORTANT: If the dome is being mounted externally using the four base holes, use the supplied rubber o-rings within each of the four mounting holes of the dome base to ensure moisture resistant seals (see Fig. C overleaf).

5. Connect the wiring

Feed the preconnected main lead (that terminates in connections F1 and F2) through the knock-out hole and connect it to your video out and power in cables. A wire-ended adaptor lead (F8) is supplied for use with power supply cables that are not terminated with an appropriate power connector (For 12 VDC operation: Connect the red lead to +ve and the black lead to -ve. For 24 VAC connection, polarity is not important). **IMPORTANT:** The power supply must be Class 2 certified. **IMPORTANT:** If the dome is being mounted externally, use a suitable sealant around the cable access hole to ensure a moisture resistant seal.

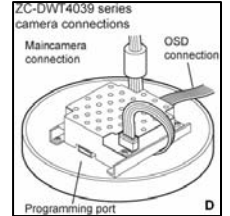

6. Fit the camera assembly

Connect the camera to the fly-connector (F4). For ZC-DWT4039 series camera only: also connect the OSD lead (F6) between the camera and the middle socket of the smaller circuit board. Place the complete camera assembly (G1) onto the three mounting pillars within the enclosure. Note: Gimbal screws are supplied with both the housing and the camera assembly (when supplied separately), therefore, you should have three screws left over.

7. Remove the camera liner

Lift the camera liner (H1) from the chassis (H2) to provide full access to the camera.

8. Adjust the camera position and test

Rotate and pan the camera chassis to the required position and then tighten the camera chassis locking screws.

Note: For specific camera adjustments (i.e. focusing and settings), please see the Camera Sheet.

9. Replace the camera liner

Carefully fit the camera liner (J1) over the focused camera so that it is fully seated on the top ring of the camera chassis (J2) and provides an unobstructed view for the camera lens.

10. Replace the dome cover

Replace the dome cover (four small internal ribs within the cover locate within four corresponding index slots (E6) within the enclosure body; these restrict the lid to only four possible orientations and ensure that the cover screw holes are correctly aligned). Use the supplied Torx bit to tighten the four cover screws - **DO NOT OVERTIGHTEN**.

